



Broaster[®] Ventless Fryer—VF-3

Standard Features



- *Space-Saving design* for back-counter operation.
- *Specifically designed for convenient production* – cooks up to 3 pounds per load.
- *No hood required in most municipalities.*
- *Built-in fire suppression system* in accordance with NFPA 17A and resettable high temp limit switch for added safety.
- *HEPA and charcoal 2-stage air filter cartridge for ventless operation.*
- *Easy to operate* – Temp-N-Time™ feature offers the capability to pre-program up to 10 different cook cycles for quick and easy preparation of various menu items.
- *Automatic cook cycle counter* – monitors production between filtering.
- *Easy to clean* – all interior components are easily removed and dishwasher safe.
- *Proven round cooking well design* – engineered for more uniform heat distribution, durability, and efficiency; no cold spots or corners.
- *Auto-Lift* ensures consistent product output by automatically lowering the cooking basket at the beginning of the cook cycle and raising the basket at the end.



Specifications

Model VF-3 ventless fryer includes round cooking well with 21 pound cooking oil capacity. Unit is primarily stainless steel monocoque construction with black, welded and powder-coated steel base plate. Interior cooking well tray is designed to capture spills up to 22.5 cups. Heating element is fully immersible with lift-and-lock mechanism for easy cleaning.

Programmable solid state control board includes Temp-N-Time™ controller providing 10 programmable cooking profiles. Comes with built-in automatic cook-cycle counter and set temperature capabilities to 375° F. Control integrated Information Center confirms that all critical components are installed and operating properly. Includes operator safety lockout until fault condition is corrected.

Unit is fitted with the following additional safety features: integrated ANSUL fire suppression system including

on-board canister and two fusible links in cooking and air-handling zones to meet NFPA 17A standards; redundant electrical controls managed by two interlocked contactors; fail safe high-limit thermostatic control with manual and remote reset features.

Three-stage air filtration system is powered by a ball bearing radial blower moving 55 CFM of air through the cooking chamber. System includes an easily removable and washable centrifugal grease extraction and flame suppression filter. There is also a two stage replaceable air filter cartridge. Filter cartridge captures over 80% of allowable particulate emissions and includes high grade HEPA media and activated carbon.

Equipment is covered by manufacturer's 1 year parts and labor warranty on all systems with additional 1 year on controller parts.

Broaster® Ventless Fryer—VF-3

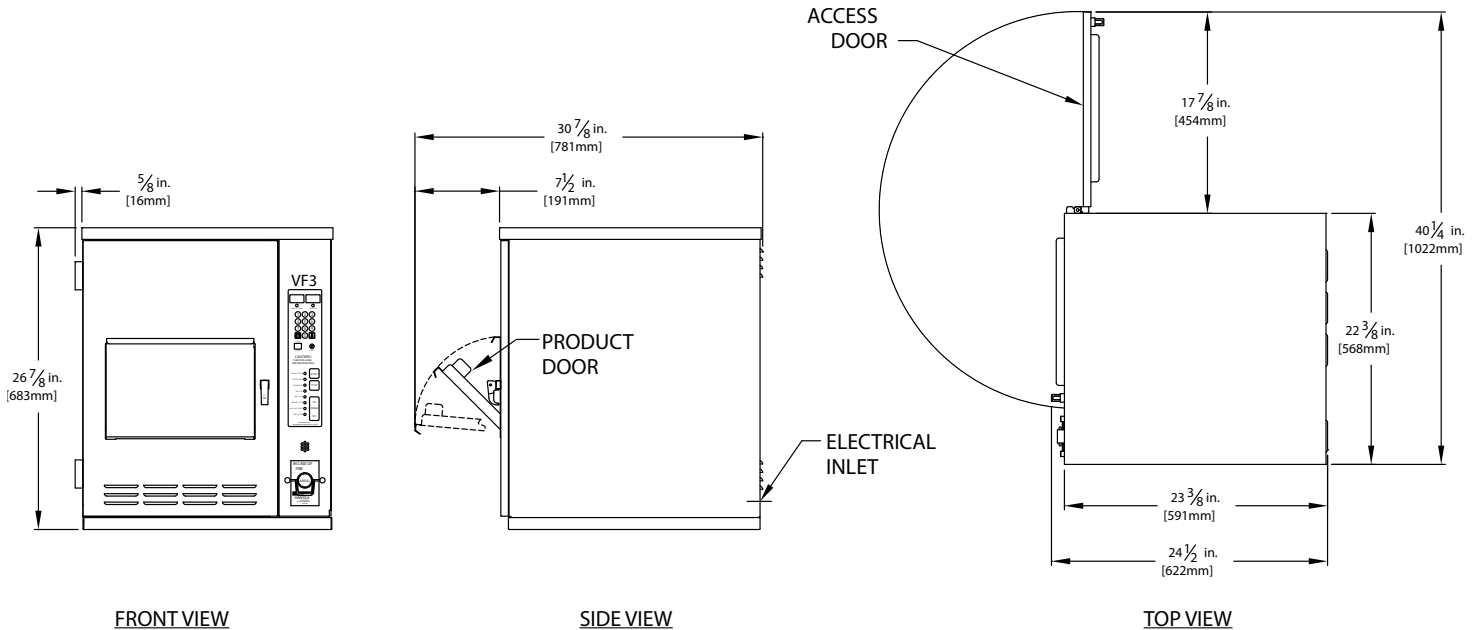

Dimensions

Model	Capacity	Cooking Oil Capacity	Overall Dimensions			Net/Ship Weight
			W	D	H	
VF-3 208v: 85902 240v: 85903	3 lbs./load 1.36 kg/load	21 lbs./2.78gal. 9.53 kg/10.52L	22-3/8" (568 mm)	23-3/8" (591 mm)	26-7/8" (683 mm)	117/171 lbs. (53.1/77.6 kg)

Energy Requirements

VF-3 5.5 kW Rated Heating Elements
 - 1 phase, 120/208 volt, 60 hz, 27 amps
 - 1 phase, 120/240 volt, 60 hz, 23 amps
 4-wire with ground and neutral
 No cord/plug provided.
 (To be field wired according to ANSI/NFPA 70 or CSA C22.2)

Additional Features

- Information Center provides at-a-glance monitoring of all critical systems.
- Convenient front product door for ease of loading and unloading.
- Oil level “dipstick” to insure proper cooking levels.
- Coated basket handle for operator comfort and safety.

Complete Start-up Accessory Kit



Accessories & Options Available

- Removable basket cover to keep products submerged while cooking
- Complete Start-up accessory kit